



ESTES INDUSTRIES  
1295 H Street  
Penrose, CO 81240

(10-98) 83998

EST 2157

©1998 Centuri Corp. All rights reserved.



S E R I E S

SKILL LEVEL 4

# 30th Anniversary Apollo 11 Saturn V

## FLYING MODEL ROCKET KIT

On May 25th, 1961 President John F. Kennedy issued a challenge to Congress that he felt would "... hold the key to our future on Earth." The call to put a man on the moon was sounded, and the answer still resounds throughout the world today. It is hard to imagine the incredible effort it took to make "... one small step for man, one giant leap for mankind." At the time the decision was made to undertake a manned lunar landing, nothing even close to a rocket with the necessary capabilities existed. After an intensive evaluation and development process, the Saturn V was ultimately chosen as the best course of action.

On July 16th, 1969 the Saturn V launched Apollo 11 into space and history. It is truly mind boggling to attempt to conceive the influences still apparent in everyday life thanks to that mission, and even harder to believe that it was 30 years ago. Here at Estes Industries we have decided to take a look back in order to imagine the future. The Saturn V has remained a much sought after kit throughout the years. We believe this is because the Saturn V ignites the imagination. Having accomplished putting a man on the moon reminds us all that the possibilities are endless. Enjoy building your 30th Anniversary Apollo 11 Saturn V, and all the dreams it may inspire.

### MATERIALS REQUIRED:

#320 & #400 SANDPAPER, PENCIL, TWEEZERS, HOBBY KNIFE (SEVERAL SHARP BLADES), YELLOW GLUE, TUBE-TYPE PLASTIC CEMENT, LIQUID PLASTIC CEMENT, PERMANENT SPRAY ADHESIVE (NOT ARTIST'S OR REPOSITIONABLE), CA, and CA for PLASTICS, CA ACCELERATOR, CA ACCELERATOR FOR PLASTICS, SANDING SEALER OR SANDABLE AUTO PRIMER, SQUADRON GREEN OR WHITE PUTTY, MASKING TAPE, SMALL PAINT BRUSH, FLAT BLACK ENAMEL BOTTLE PAINT AND SPRAY PAINT, FLAT WHITE ENAMEL BOTTLE PAINT AND SPRAY PAINT, ENAMEL SILVER SPRAY PAINT (OPTION: YOU MAY ALSO WANT BOTTLE SILVER), OR ENAMEL GUNMETAL SPRAY PAINT INSTEAD OF SILVER, "DULLCOTE" SPRAY PAINT (BE SURE TO FOLLOW INSTRUCTIONS AND CAUTIONS), DO NOT USE LACQUER BASED PAINTS! THEY CAN "CRAZE" THE SURFACE OF THE PLASTIC PARTS. 1/4" (6 mm) LAUNCH ROD (WE RECOMMEND THAT YOU USE THE NORTH COAST ROCKETRY® MODULAR™ LAUNCH PAD AND ROD.)

Please be extremely careful using cyanoacrylate adhesive (CA). Avoid getting in your eyes or on your skin. Safety glasses are recommended. Use adhesives and paint only in areas with adequate ventilation.

Be sure to read all instructions, test fit all parts, and sand if necessary before gluing.

**Note:** Before beginning to build with vac-formed plastic parts, read the following sections carefully.

#### Cutting Vac-Formed Parts

Cutting vac-formed plastic parts requires patience. Applying light pressure, make repeated passes with the blade to cut through the plastic. Be sure to keep the blade in the same cut line each time; too much pressure will cause the blade to move and not cut cleanly.

#### Sanding and Trimming Vac-Formed Parts

Once the part is free of excess plastic, sand the edges to remove any flash and to provide a smooth, flat bonding surface. Secure a sheet of #220 or #320 grit sandpaper to a flat surface. (You may want to use wet-or-dry sandpaper with a little water to avoid clogging or loading the sandpaper with plastic dust.) Move each part in a circle against the sandpaper with pressure evenly distributed to avoid uneven sanding. Applying too much pressure can cause uneven edges. When working with thin edges, be careful not to remove too much plastic or generate too much heat that may warp and destroy the part. NOTE: Double sided tape may be used to hold small parts. Use a file to remove excess plastic on hard to hold small parts.

#### Adhesives for Vac-Formed Parts

Because vac-formed parts are thinner than injection molded parts, different adhesives should be used. Two basic types give good results and you should have both on hand when building this model.

First is liquid plastic cement. Our preferred brands are Plastic Weld Cement (Plastruct), Testor's Plastic Cement #3502, Microweld (Kassel Industries), Tenax TR-7, and Testor's or Tamiya glue pens. Liquid cements work on styrene by dissolving the plastic and creating a chemically welded bond. As a result, a little bit goes a long way! Liquid cements are usually applied with an artists brush. The trick to using plastic cement is to take advantage of the liquid flowing out from the brush by allowing cement to bleed into close fitting parts and then squeezing the parts together to bond. Work on a small area at one time as plastic cement sets quickly.

The second adhesive to have on hand is a super glue or cyanoacrylate for plastics. We recommend Pic Plasti-Stic or Plasti-Zap. You'll also want to use CA accelerators for plastics for these, but use a toothpick or a pipette to apply accelerator one drop at a time. When sprayed from their normal applicators, most regular CA accelerators will soften and stain plastic surfaces.

#### Filling the Seams

This is a necessary step in constructing vac-formed models. Because these models have seams, they need to be filled and smoothed. The putties we recommend are 3M Accyl-Blue (Usually found at auto body supply shops - one tube will last a long time!) and Squadron Green or White Putty (usually found in hobby shops.)

When working with putty or filler use as little as possible. Excess putty in a seam creates extra work in sanding it away, as well as the possibility of a "sinkhole" (where the putty collapses the skin of the plastic and eats it away.) Use masking tape along seams to minimize excess putty from adhering to the work area. Use multiple layers when building up low areas, rather than one thick layer of putty. Doing so will reduce shrinkage, cracking, and the risk of sinkholes. Let the putty dry overnight before attempting to sand it away. Wet-or-dry sandpaper, used wet, works best. Start with #220 grit and work your way through #320 to #400. Then polish the area with #600.

# PARTS LAYOUT



THIRD STAGE  
COUPLER 80C (1)  
30274

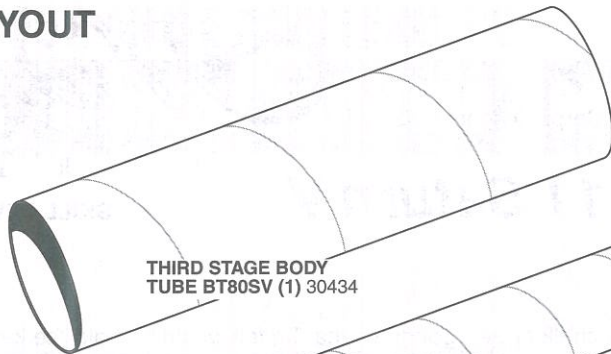

THIRD STAGE BODY  
TUBE BT80SV (1) 30434

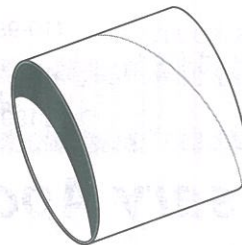

SPACER RING 90SV  
[DISPLAY COUPLER]  
(1) 30460



LM/SM BODY TUBE  
BT58SV6 (1) 30466

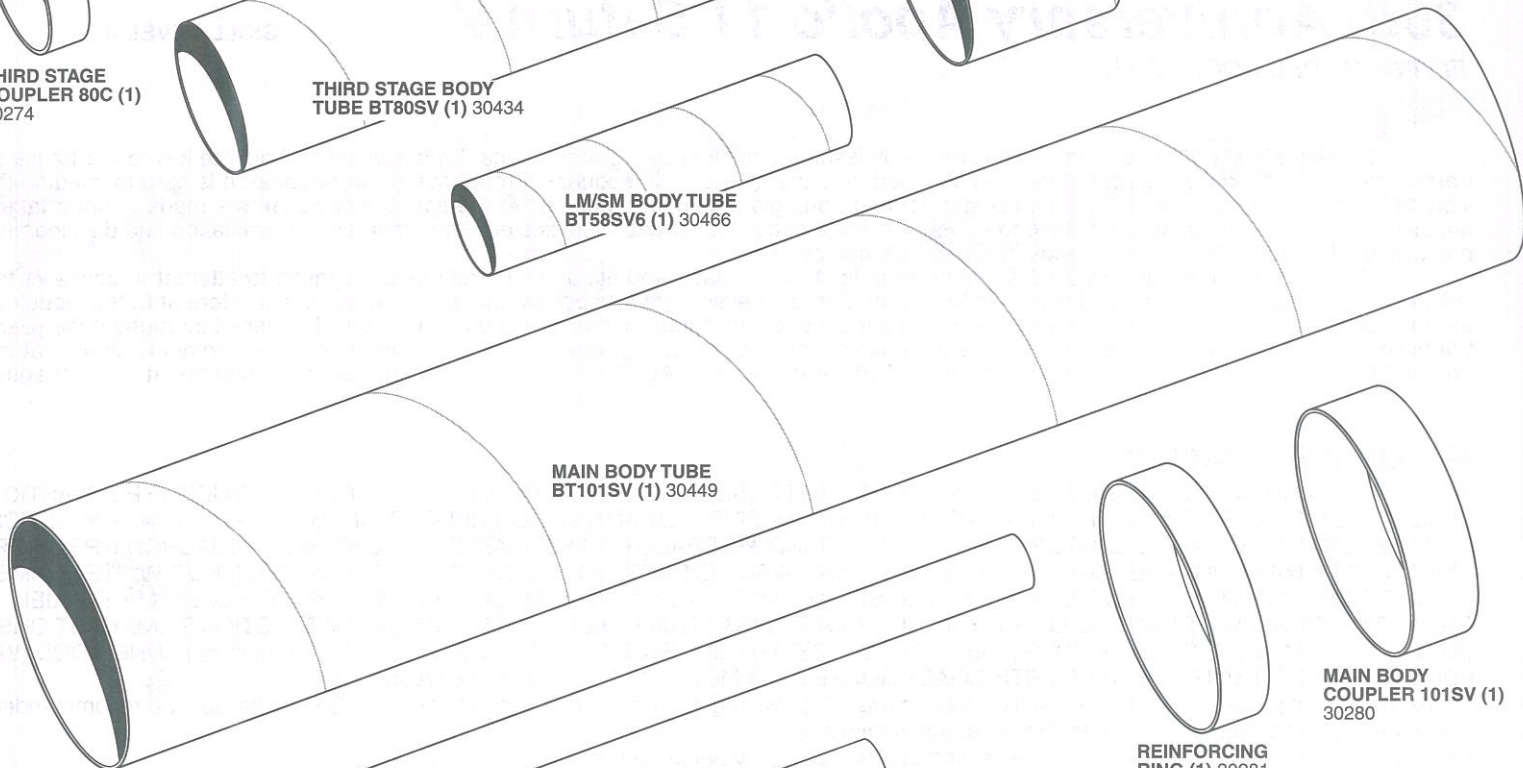

MAIN BODY TUBE  
BT101SV (1) 30449

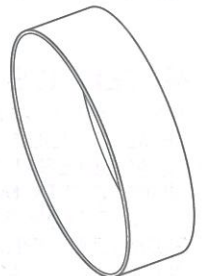

MAIN BODY  
COUPLER 101SV (1)  
30280



REINFORCING  
RING (1) 30281

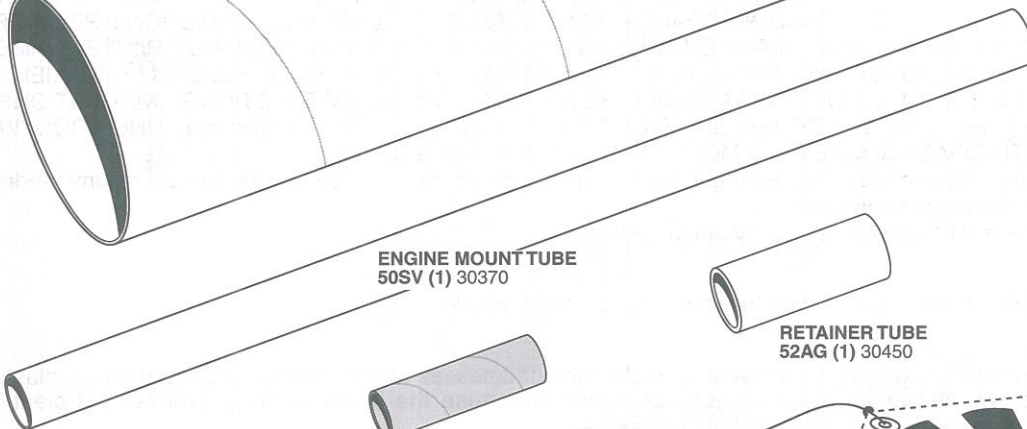

ENGINE MOUNT TUBE  
50SV (1) 30370



RETAINER TUBE  
52AG (1) 30450

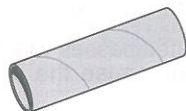

YELLOW ENGINE SPACER  
TUBE ET6 (1) 35004



THRUST RING  
2050 (1) 30164-2

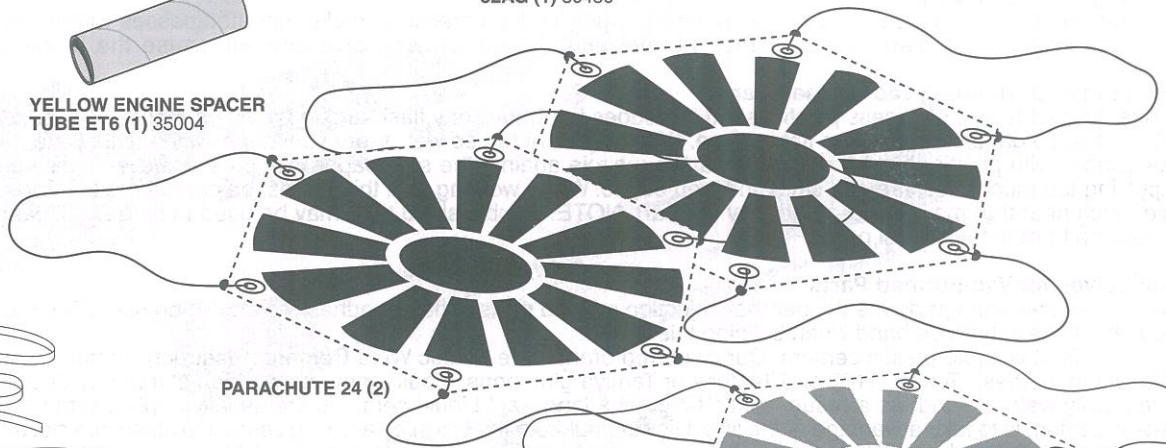

PARACHUTE 24 (2)

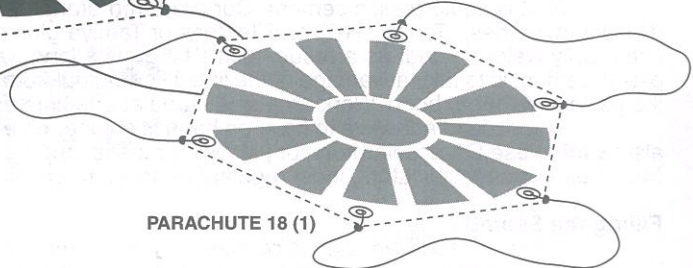

PARACHUTE 18 (1)

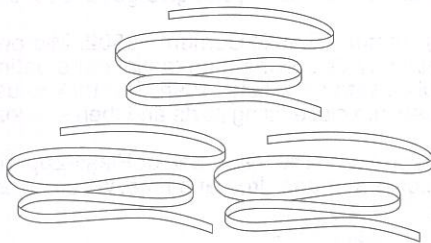

SHOCK CORD 1/4 x 36 (3) 38382



BRASS WIRE (1)  
38331

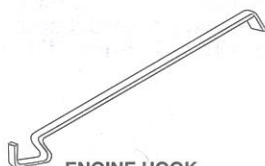

ENGINE HOOK  
EH-2A (1) 35021



SNAP SWIVEL (1) 38265



LAUNCH LUGS  
HLL2754 (2) 38181

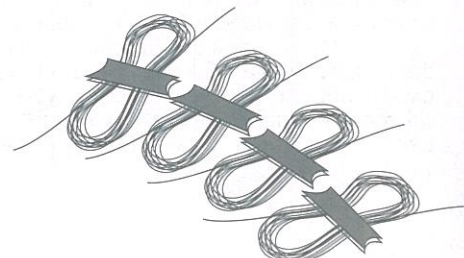

SHROUD LINE (4 BUNDLES) 38241

**DIE CUT CARDS**

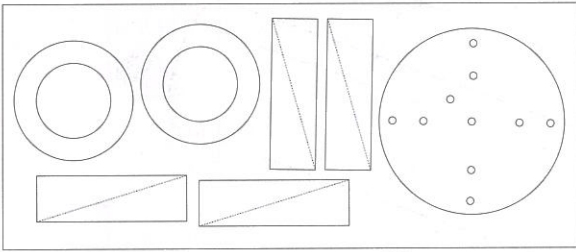

#32472 (NOZZLE BULKHEAD, LEM/SM CENTERING RINGS, FAIRING GUSSETS)

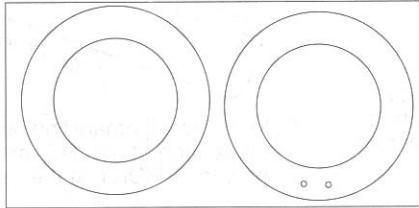

#32471 THIRD STAGE CENTERING RINGS)

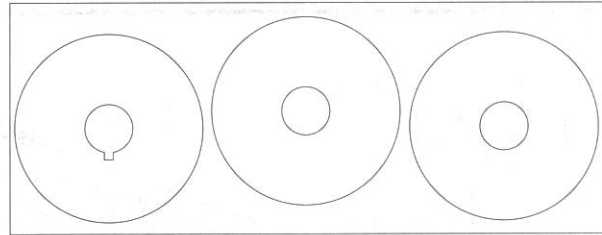

#32473 (ENGINE MOUNT CENTERING RINGS)

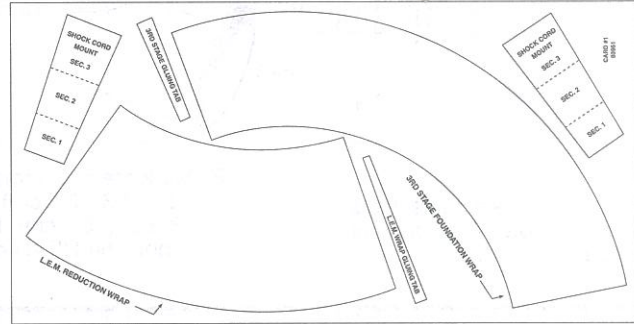

#83591 PRINTED CARD (SHOCK CORD MOUNTS, 3RD STAGE FOUNDATION WRAP, L.E.M. REDUCTION WRAP)

**VACUUM FORMED PARTS**

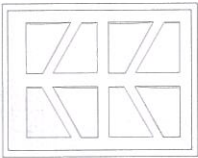

32851 FIN SHEET

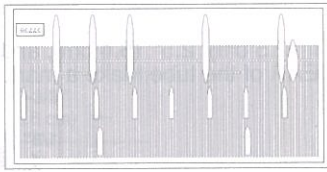

32855 INTER STAGE WRAP

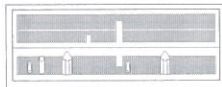

32856 UPPER 3RD STAGE WRAP/  
LOWER 3RD STAGE WRAP



32857 BODY WRAP REDUCTION

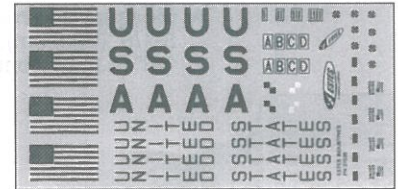

DECAL SHEET (1) 37038

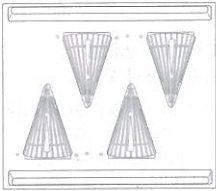

32852 FAIRING SHEET



32854 INTER TANK WRAP/  
UPPER 2ND STAGE WRAP

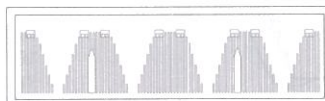

32853 LOWER 1ST STAGE WRAPPER

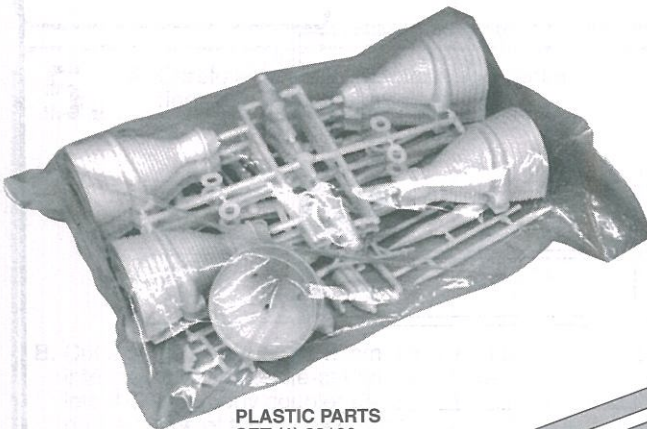

PLASTIC PARTS  
SET (1) 33100

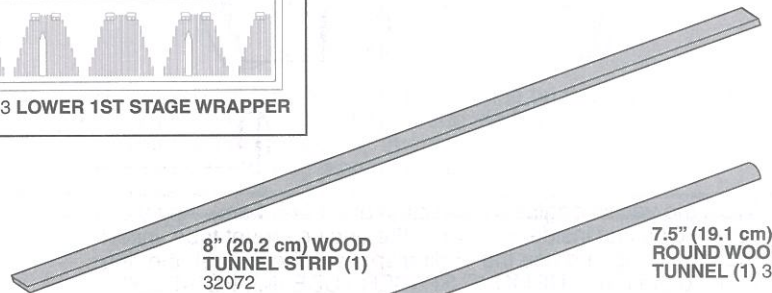

8" (20.2 cm) WOOD  
TUNNEL STRIP (1)  
32072

7.5" (19.1 cm) HALF  
ROUND WOOD  
TUNNEL (1) 32071

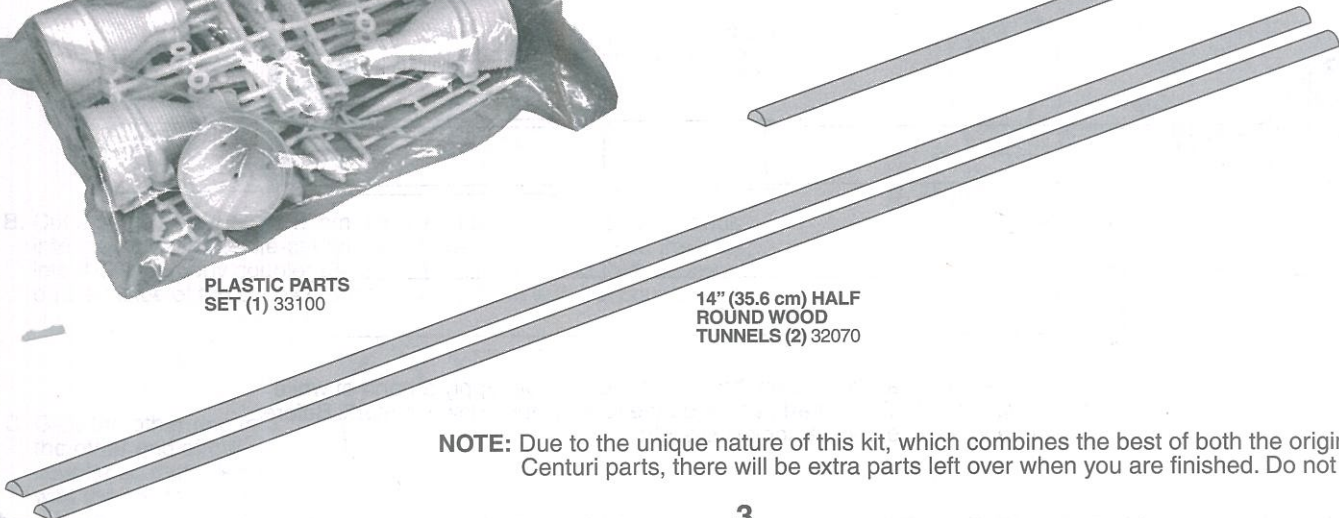

14" (35.6 cm) HALF  
ROUND WOOD  
TUNNELS (2) 32070

**NOTE:** Due to the unique nature of this kit, which combines the best of both the original Estes and Centuri parts, there will be extra parts left over when you are finished. Do not be concerned.

# ASSEMBLY BE SURE TO READ ALL INSTRUCTIONS, TEST FIT ALL PARTS, AND SAND IF NECESSARY

## 1.

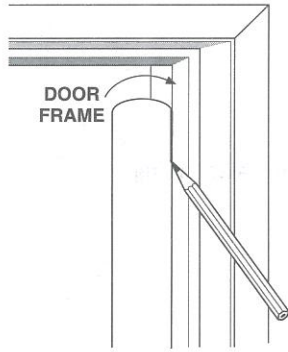

**A.** Use a door frame as a guide to draw a straight line down the main and third stage body tubes.

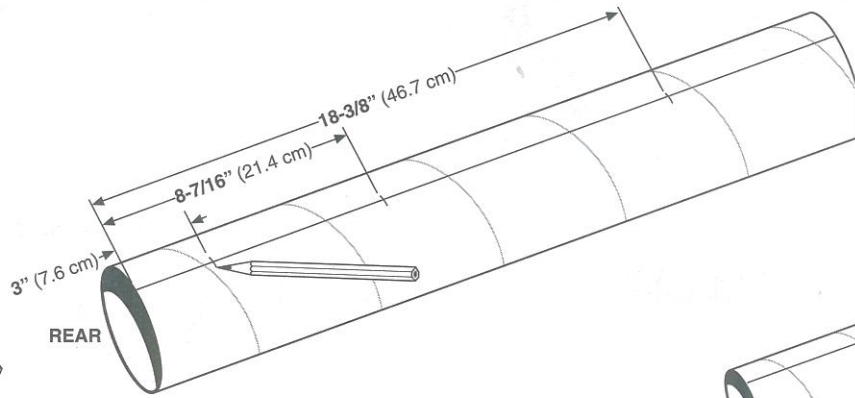

**B.** Mark the alignment line on the main body tube at 3" (7.6 cm), 8-7/16" (21.4 cm), and at 18-3/8" (46.7 cm). The end you measure from is now the REAR of the tube.

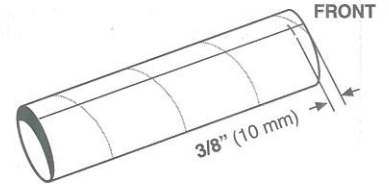

**C.** Mark the alignment line on the third stage tube at 3/8" (10 mm). This is now the FRONT of the tube.

## 2.

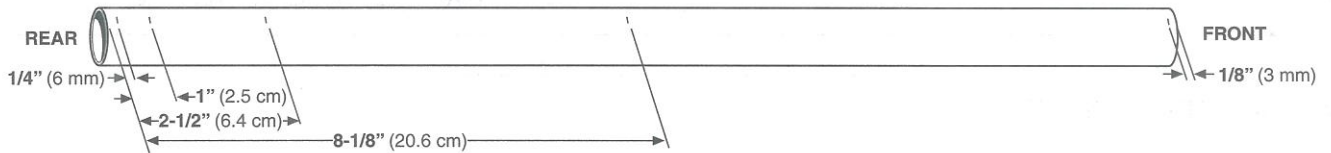

**A.** Measure and mark the engine mount tube at 1/4" (6 mm), 1" (2.5 cm), 2.5" (6.4 cm), and at 8-1/8" (20.6 cm). The end you measured from is now the REAR of the tube. Make a mark at 1/8" (3 mm) from the front of the tube.

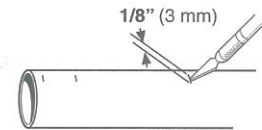
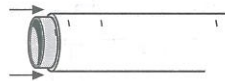
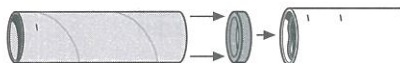
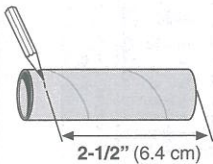

**C.** Use a hobby knife to cut a 1/8" (3 mm) wide slit in the engine mount tube at the 2-1/2" (6.4 cm) mark ONLY.

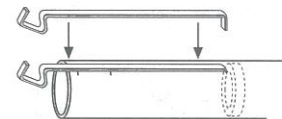

**D.** Insert the engine hook as shown.

**B.** Mark the yellow engine spacer tube at 2.5" (6.4 cm). Apply a ring of glue just inside the rear of the engine mount tube, insert the thrust ring and use the engine spacer tube to push the ring in up to the mark. REMOVE SPACER TUBE IMMEDIATELY!

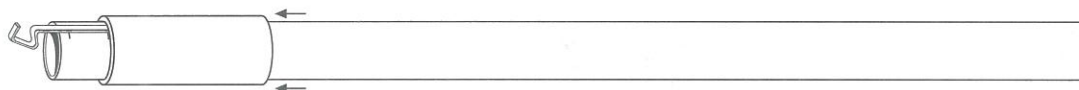

**E.** Slide the retainer tube part way down the engine mount tube, apply a band of white glue just above the 1" (2.5 cm) mark, and slide the retainer tube down to mark. Before glue dries, check that the engine hook is straight.

- 3.** A. Use a hobby knife to carefully remove the centering rings from their die-cut card, test fit onto engine mount tube, and sand as necessary.

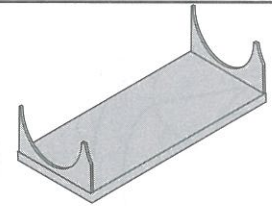
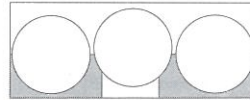
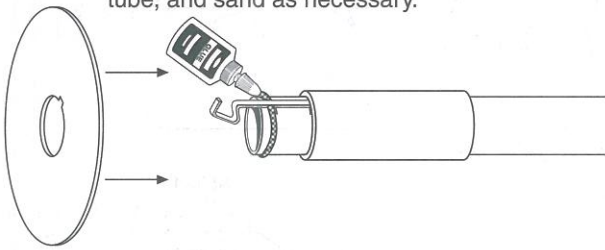

**OPTIONAL STEP:** A cradle for holding the body assembly is very handy. To make a cradle, use a piece of wood about 4" wide x 15" long (10 cm wide x 38 cm long). Cut two pieces from the die cut card as shown and glue to the wood as shown to complete cradle.

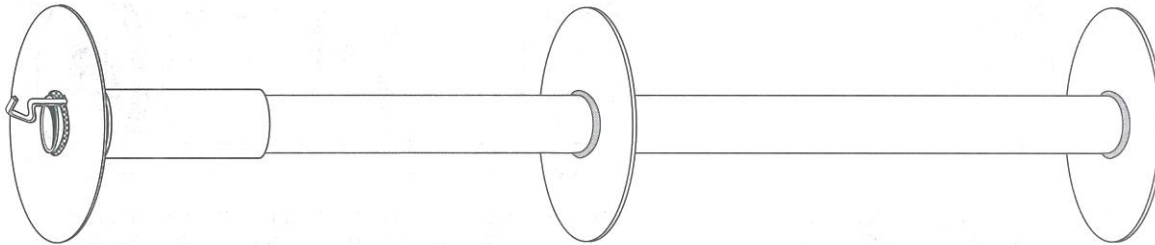

- B. Apply a band of yellow glue around the engine mount tube just behind the 1/4" (6 mm) mark (do not get glue on engine hook). Then slide the notched ring over the engine hook and position at the 1/4" (6 mm) mark. Check that the ring is perfectly perpendicular to the tube all the way around and the notch is over the engine hook. Glue the remaining centering rings at the 8-1/8" (20.6 cm) mark and at 1/8" (3 mm) from the front of the tube, making sure the rings are straight. Let dry, then fillet all of the ring/tube joints.

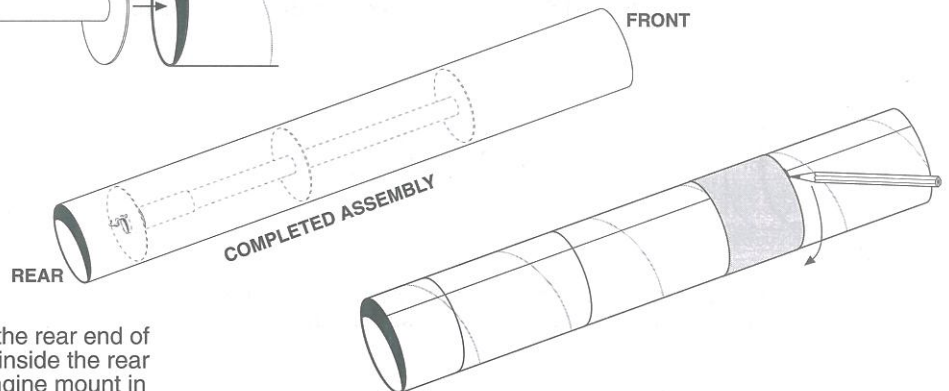
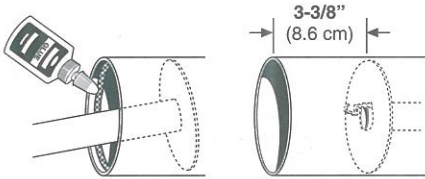
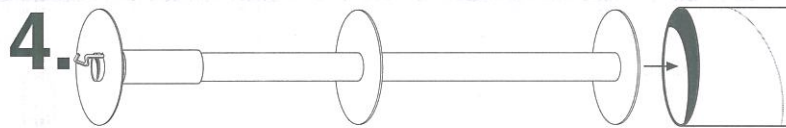

- A. Slide the front ring on the engine mount into the rear end of the main body tube, apply a ring of glue just inside the rear of the body tube, then slide the rest of the engine mount in until the rear ring is 3-3/8" (8.6 cm) from the rear end of the body tube. Apply a bead of glue to the ring/tube joints at each end, let dry, then fillet the joints.

- B. Carefully extend the marks you made on the main body tube alignment line all the way around the tube, making sure the rings you draw are straight. (You may want to use a thick piece of paper or masking tape as an aid in drawing the rings.)

- 5.** A. Carefully remove the third stage centering rings from their die-cut card.

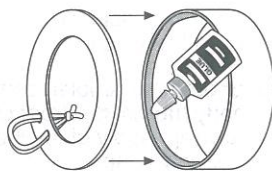

- B. Cut a piece of line 5" (12.7 cm) long, double it, and thread the ends into the holes in the die-cut ring as shown. Test fit and glue the ring into the main body coupler (3-15/16" [10 cm] long) so that the knot is on the inside of the coupler and the ring is flush with the coupler edge.

- C. Glue the other ring into the other end of the coupler so that it is flush with the coupler edge.

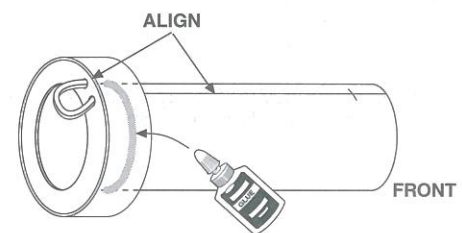
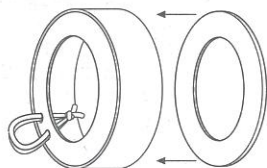

- D. Align the reference line you drew earlier on the third stage body tube with the string loop, and glue the tube into the coupler assembly. (Be sure to note the front of the tube.) Let dry.

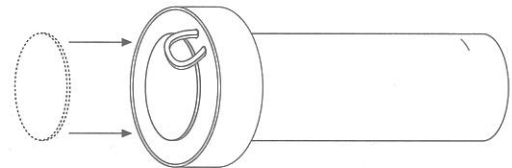

- E. Glue the center from one of the die-cut rings onto the bottom of the tube/coupler assembly.